

Physikalisch-Technische Bundesanstalt
Fertigungsmeßtechnik

PTB-Bericht F-37

Calibration of a step gauge
Final Report of EUROMET Project #372

by

Otto Jusko

Content

1	Introduction.....	3
2	Official Participants.....	4
3	Time schedule.....	5
4	Measurement Standard.....	6
5	Measurement instructions and reporting.....	7
6	Measurement methods and instruments used by the participants.....	8
7	Condition and stability of the standard.....	10
8	Measurement results.....	13
8.1	Thermal expansion coefficient.....	13
8.2	Dimensional calibration.....	13
9	Evaluation of the reference results.....	22
10	Measurement uncertainty.....	23
	Annex 1 : Second measurement of NPL.....	25

1 Introduction

In November 1995, the EUROMET contact persons for length decided to carry out an interlaboratory comparison for the calibration of a step gauge. Seven European national metrology institutes agreed to participate. The German Physikalisch-Technische Bundesanstalt (PTB) was the pilot laboratory.

The comparison started in March 1996 with the circulation of a 420 mm-"KoBa"-step-gauge . The pattern of the comparison was chosen as a circulation type with an initial and a final calibration by the pilot laboratory.

2 Official Participants

Laboratory Code	Country Code	Contact person, Laboratory	Phone, Fax, email
SP	SE	Mathias Johansson Swedish National Testing and Research Institute P.O. Box 857 S-50115 Boras Sweden	Tel. +46-33 165496 Fax +46-33 106973 Mikael.Frennberg@sp.se
NMi	NL	Han Haitjema NMi Van Swinden Laboratorium Postbus 654 NL-2600 AR Delft Netherlands	Tel. +31-152 691 641 Fax +31-152 612 971 han.haitjema@nmi.nl
IMGC	IT	Bruno I. Rebaglia Istituto di Metrologia G. Colonnetti Strada delle Cacce 73 I-10135 Torino Italy	Tel. +39-11 3977 468 Fax +39-11 3977 459 Rebaglia@imgc.to.cnr.it
CEM	ES	Emilio Prieto Centro Español de Metrologia C/del Alfar, 2 28760 Tres Cantos Spain	Tel. +34-91 8074 716 Fax +34-91 8074 807 eprieto@mfom.es
NPL	UK	Graham Peggs National Physical Laboratory Queens Road Teddington Middlesex TW11 0LW United Kingdom	Tel. +33-181 977 3222 Fax.+41-181 943 7458 graham.peggs@npl.co.uk
OFMET	CH	Ruedi Thalmann Swiss Federal Office of Metrology Lindenweg 50 CH-3003 Bern - Wabern Switzerland	Tel. +41-31 323 33 85 Fax +41-31 323 3210 rue-dolf.thalmann@eam.admin.ch
Coordinator:			
PTB	DE	Otto Jusko Physikalisch-Technische Bundesanstalt Postfach 3345 D-38023 Braunschweig Germany	Tel. +49-531 592 5211 Fax +49-531 592 5305 otto.jusko@ptb.de

3 Time schedule

The original time schedule had foreseen about two month for each laboratory for the calibration **including the transportation**. Due to the inclusion of additional laboratories and the limited availability of other participants, the original time schedule of the first loop was revised during the circulation. The following table shows the effective measurement date for each laboratory.

Laboratory	Country	Date of measurement
PTB	Germany	March 1996
SP	Sweden	May 1996
NMi	Netherlands	July 1996
OFMET	Switzerland	September 1996
CEM	Spain	December 1996
IMGC	Italy	January 1997
NPL	United Kingdom	March 1997
PTB	Germany	July 1997
PTB	Germany	October 1998

4 Measurement Standard

The only circulated artefact was a step-gauge made by Kolb & Baumann (KOBA) in Germany with a nominal length of 420 mm. The step-gauge has a steel frame with a groove where the 11 gauge cylinders are fixed by clamping.

The step-gauge has the serial-number: 969112/64K

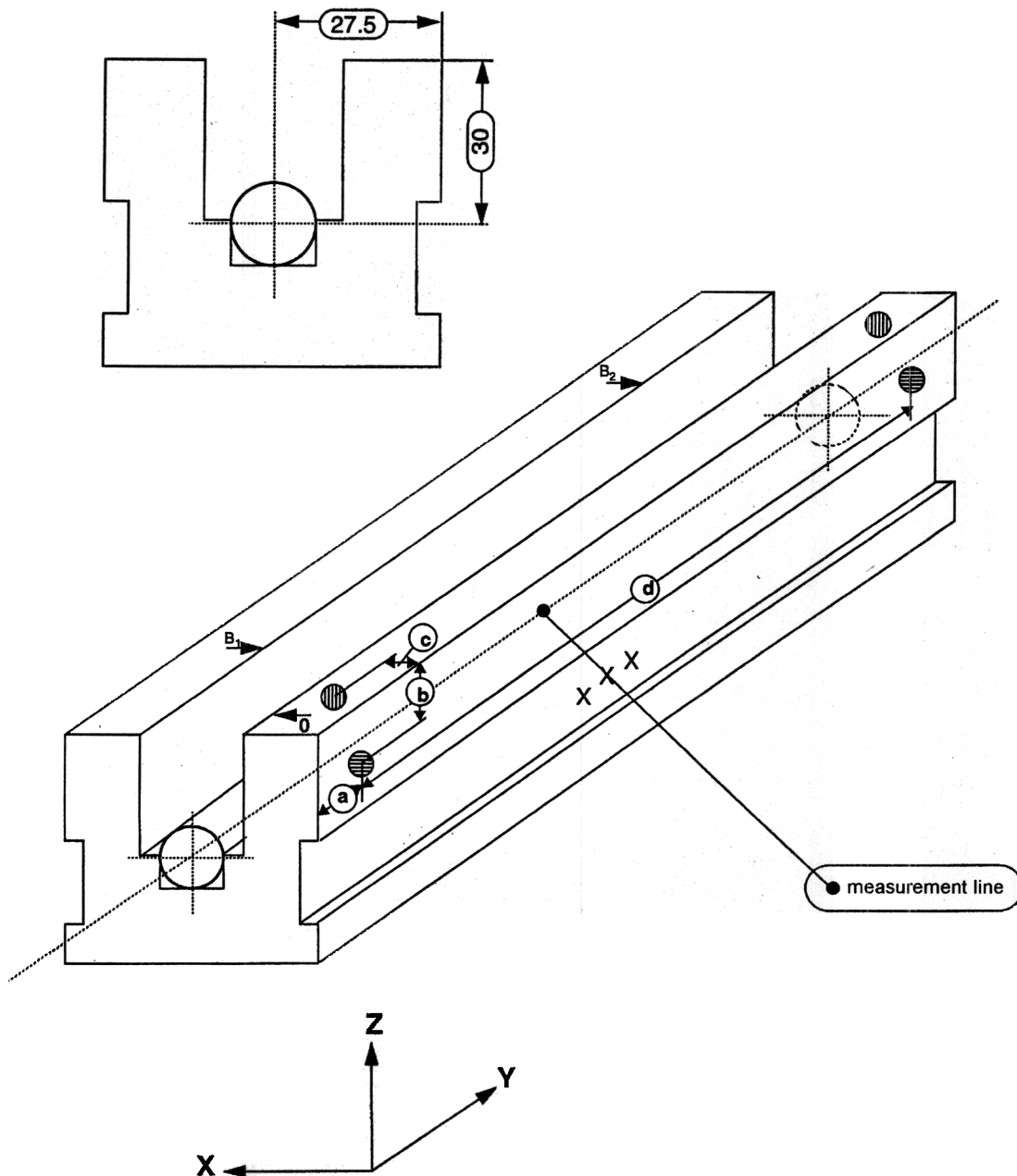

Fig.1

Drawing of a KOBA step-gauge

5 Measurement instructions and reporting

The participants were told to calibrate the centre distances of all the 22 front and back faces of the gauge cylinders with respect to the first front face, No. 0. No special alignment conventions were given. Such the results should reflect the standard calibration procedure performance of all participants.

If the participating laboratory is able to calibrate also the thermal expansion coefficient of the frame it should do so. It was not clarified before the circulation which laboratories could measure this measurand.

6 Measurement methods and instruments used by the participants

- SP** Commercial length measurement machine ULMM-3000 (Carl Zeiss Jena) combined with two HP laser interferometers, working as linear Abbe-comparator.
Edlén-based refraction correction
Contact sphere \varnothing : 3 mm
Alignment was on the upper and on the front side with the frame supported at the Bessel points
- NMi** Commercial CMM equipped with laser-interferometer
Edlén-based refraction correction
Alignment with respect to outer frame
- IMGC** Numerically controlled Moore n3 measuring machine. Displacement measured by laser interferometer. Probe system: Cary 1-Dim, resolution 0.01 μm , calibrated against laser interferometer.
Edlén-based refraction correction and tracking refractometer
Contact sphere \varnothing : 3 mm (ruby)
- CEM** Custom-built length comparator CEM-TEK 1200 equipped with laser-interferometer, two beam pseudo-Abbe - measurement principle.
Alignment with respect to outer frame with alignment check
Edlén-based refraction correction and tracking refractometer
- NPL** Custom-built multi-axis measuring machine equipped with laser-interferometer
Alignment with respect to outer frame
Edlén-based refraction correction
- OFMET** Length Measuring machine designed by SIP and OFMET, based on coordinate measuring machine SIP CMM5. Displacement measurement using plane mirror interferometer. Inductive probe Cary 1-Dim. Probe diameter calibration using 5 mm gauge block [R. Thalmann, "A new high precision length measuring machine", Proc. IPES9 conference, Braunschweig 1997].

Edlén-based refraction correction

Alignment with respect to upper and side face of the frame.

PTB Two independent Custom-built step-gauge length-comparators equipped with laser-interferometers with pseudo-Abbe measurement principle. The absolute length measurement is calibrated by several gauge-blocks.

Edlén-based refraction correction

Contact sphere \varnothing : 3 mm (ruby)

Alignment with respect to side-walls of central groove

7 Condition and stability of the standard

The pilot laboratory has calibrated the step-gauge three times: At the beginning of the comparison (March 1996) after the official circulation loop (July 1997) and shortly before the writing of the document (October 1998).

In Fig. 2 the calibration differences of 1997 and 1998 of the nominal front face distances ("steps") to the first calibration in 1996 are shown. The differences are far below the calibration uncertainty of the pilot laboratory which is:

$$U = 0,2 \mu\text{m} + 0,5 * 10^{-6} * L$$

This means that the calibration values of the mean-line of the step-gauge was stable over time.

In Fig.2 the calibration differences are shown. The periodic variation in the 1998-1996 curve which is not detectable in the 1997-1996 gives rise to the assumption that the feeler constant was slightly mis-calibrated in 1998.

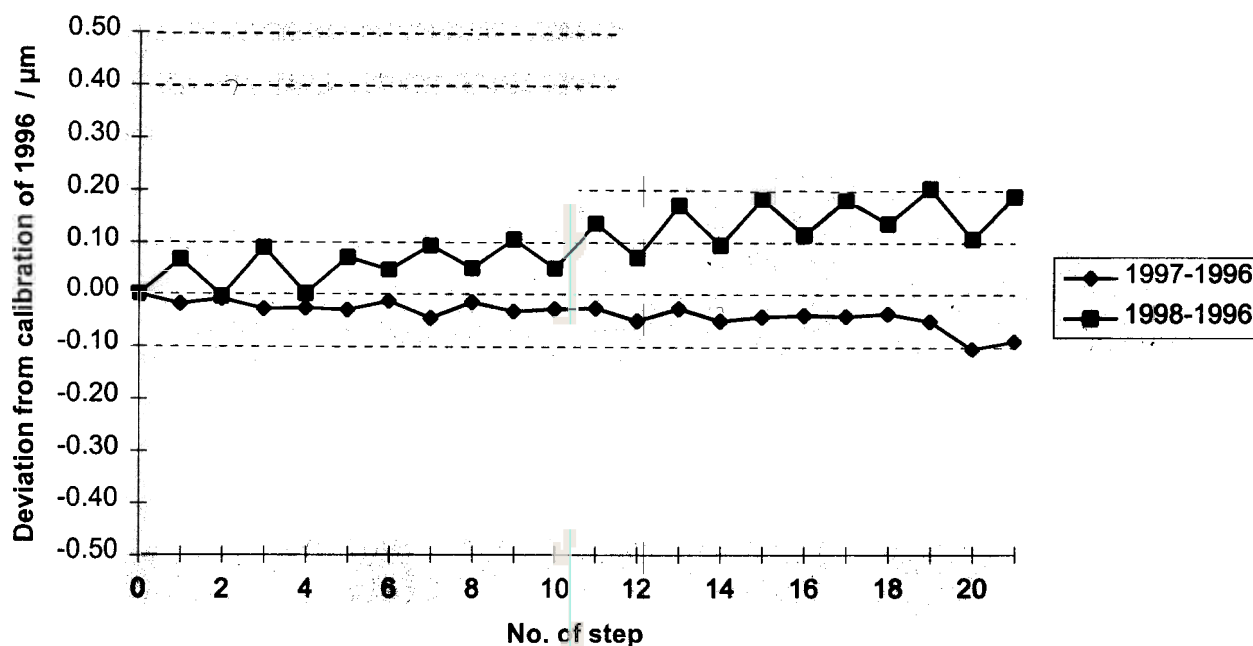

Fig.2: Stability test: Differences of the PTB calibrations of 1997 and 1998 to 1996

A further condition and stability test is the calibration at intentionally varied heights. PTB chose the heights "+2mm" (2 mm above center line) and "-2mm" (2 mm below center line). In Fig.3a the differences to the calibration result of the center line are shown for the calibration of 1996. In Fig 3b the correspondent values for 1998 are shown. Both graphs differ only slightly confirming the stability assumption.

Steps 12 and 13 appear as a large peak with alternating sign as a function of the sign of the calibration height with respect to the center line. The reason is an inclination of the gauge cylinder with respect to the nominal straight center line. The peak height can be used as a reference value for a possible height mis-alignment. For a certain calibration it can be compared to the approx. $3\mu\text{m}/2\text{mm}$ value of the PTB calibration.

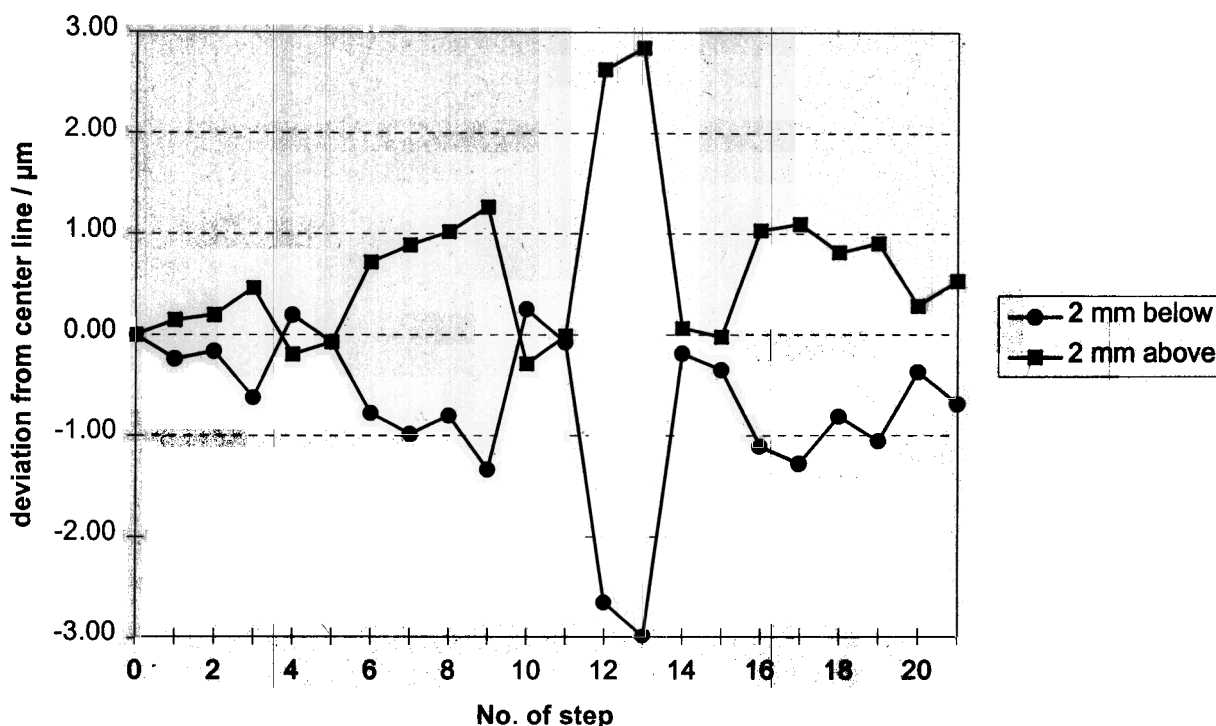

Fig.3a: Calibration at heights +/- 2mm with respect to the center line.
Calibration values of 1996

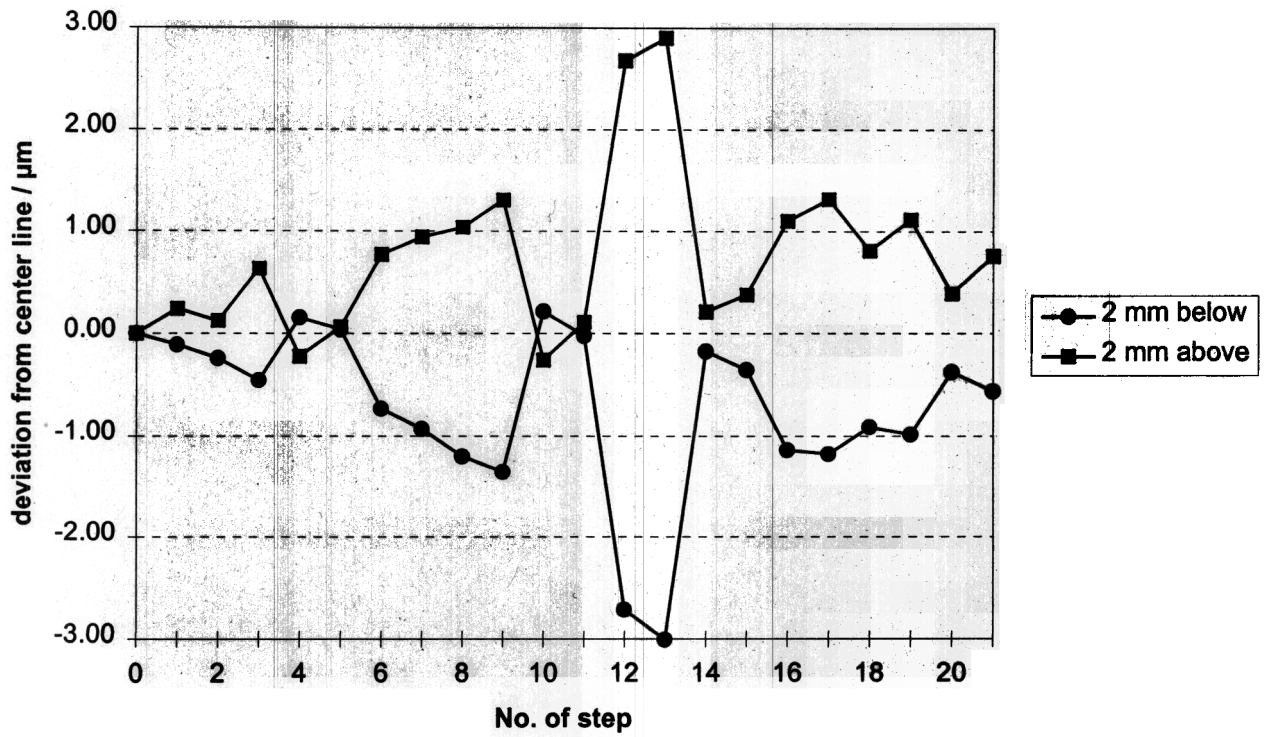

Fig.3b: Calibration at heights +/- 2mm with respect to the center line.
 Calibration values of 1998

8 Measurement results

8.1 Thermal expansion coefficient

It turned out, that only the pilot laboratory was able to measure the thermal expansion coefficient. Because the expansion coefficient calibration was performed after the circulation of the step-gauge, it was agreed by the participants to use only an estimated value of $\alpha = 11,5 * 10^{-6} K^{-1}$.

In PTB the expansion coefficient was calibrated using a simple apparatus which relies on a Zerodur rod as thermal stability reference.

The temperature was varied between 19°C and 26°C.

The resulting value for α was $11,75 * 10^{-6} K^{-1}$ with a standard uncertainty of $u = 0,05 * 10^{-6} K^{-1}$.

The difference between the estimated and the measured coefficient is significant but does not dominate the uncertainty for the length calibration.

8.2 Dimensional calibration

Table 1 contains a summary of the calibration values of the distances of the front and back faces of the gauge cylinders from all participants.

Table 3 provides the associated standard uncertainties (coverage factor $k=1$). In general, the participants stated expanded uncertainties with an expansion factor of $k=2$. In that case, the standard uncertainty ($k=1$) was calculated by dividing by 2.

An additional column is provided with the reference values calculated like explained in chapter 9.

No. of step	CEM	OFMET	IMGC	NMI	NPL	SP	PTB'96
0	0.00000	0.00000	0.00000	0.00000	0.00000	0.00000	0.00000
1	20.00091	20.00090	20.00077	20.00089	20.00140	20.00090	20.00098
2	39.95241	39.95234	39.95233	39.95243	39.95250	39.95230	39.95237
3	59.95332	59.95324	59.95312	59.95330	59.95380	59.95320	59.95336
4	79.99445	79.99449	79.99446	79.99455	79.99450	79.99460	79.99446
5	99.99449	99.99450	99.99437	99.99450	99.99490	99.99450	99.99455
6	120.03566	120.03568	120.03567	120.03576	120.03620	120.03560	120.03570
7	140.03613	140.03613	140.03604	140.03618	140.03680	140.03600	140.03624
8	160.07659	160.07655	160.07654	160.07665	160.07720	160.07640	160.07658
9	180.07712	180.07715	180.07705	180.07709	180.07790	180.07690	180.07713
10	200.11075	200.11083	200.11076	200.11088	200.11080	200.11090	200.11072
11	220.10778	220.10780	220.10765	220.10781	220.10830	220.10780	220.10778
12	240.12357	240.12349	240.12349	240.12375	240.12480	240.12330	240.12366
13	260.12439	260.12424	260.12417	260.12445	260.12570	260.12400	260.12450
14	280.14243	280.14244	280.14234	280.14252	280.14260	280.14240	280.14236
15	300.14252	300.14248	300.14235	300.14252	300.14310	300.14250	300.14245
16	320.07983	320.07982	320.07976	320.07999	320.08040	320.07980	320.07980
17	340.08061	340.08055	340.08040	340.08058	340.08140	340.08060	340.08059
18	360.12313	360.12332	360.12326	360.12345	360.12360	360.12330	360.12324
19	380.12403	380.12414	380.12401	380.12421	380.12490	380.12420	380.12417
20	400.13871	400.13869	400.13860	400.13881	400.13910	400.13870	400.13863
21	420.13950	420.13946	420.13926	420.13950	420.14010	420.13950	420.13945

Table 1: Summary of the reported calibration results of the step-gauge (in mm)

Some data files were not offset corrected. Therefore the mean value of all reported was calculated and subtracted from the data files. Table 2 presents the resulting values and the reference value for comparison. For better comparability to Table 1 an (arbitrary) offset of 420/2 to the offset corrected values was added (one half of the max. nominal value) was added.

No. of step	CEM	OFMET	IMGC	NMI	NPL	SP	PTB'96	Reference
0	-0.07083	-0.07083	-0.07075	-0.07090	-0.07136	-0.07079	-0.07085	-0.07083
	19.93008	19.93007	19.93002	19.92999	19.93004	19.93011	19.93013	19.93006
2	39.88158	39.88151	39.88159	39.88153	39.88114	39.88151	39.88152	39.88156
3	59.88249	59.88241	59.88238	59.88240	59.88244	59.88241	59.88251	59.88245
4	79.92362	79.92366	79.92371	79.92365	79.92314	79.92381	79.92361	79.92364
5	99.92366	99.92367	99.92363	99.92360	99.92354	99.92371	99.92370	99.92365
6	119.96483	119.96485	119.96492	119.96486	119.96484	119.96481	119.96485	119.96485
7	139.96530	139.96530	139.96530	139.96528	139.96544	139.96521	139.96539	139.96530
8	160.00576	160.00572	160.00580	160.00575	160.00584	160.00561	160.00573	160.00575
9	180.00629	180.00632	180.00630	180.00619	180.00654	180.00611	180.00628	180.00627
10	200.03992	200.04000	200.04002	200.03998	200.03944	200.04011	200.03987	200.03995
11	220.03695	220.03697	220.03690	220.03691	220.03694	220.03701	220.03693	220.03694
12	240.05274	240.05266	240.05274	240.05285	240.05344	240.05251	240.05281	240.05275
13	260.05356	260.05341	260.05343	260.05355	260.05434	260.05321	260.05365	260.05351
14	280.07160	280.07161	280.07159	280.07162	280.07124	280.07161	280.07151	280.07159
15	300.07169	300.07165	300.07161	300.07162	300.07174	300.07171	300.07160	300.07165
16	320.00900	320.00899	320.00902	320.00909	320.00904	320.00901	320.00895	320.00901
	340.00978	340.00972	340.00965	340.00968	340.01004	340.00981	340.00974	340.00973
18	360.05230	360.05249	360.05252	360.05255	360.05224	360.05251	360.05239	360.05242
19	380.05320	380.05331	380.05327	380.05331	380.05354	380.05341	380.05332	380.05326
20	400.06788	400.06786	400.06786	400.06791	400.06774	400.06791	400.06778	400.06787
21	420.06867	420.06863	420.06851	420.06860	420.06874	420.06871	420.06860	420.06862

Table 2: Original calibration data minus column mean + 420/2 (in mm)

No. of step	CEM	OFMET	IMGC	NMI	NPL	SP	PTB
0	0.06	0.15	0.10	0.10	0.10	0.30	0.10
1	0.06	0.15	0.10	0.10	0.10	0.30	0.11
2	0.06	0.15	0.11	0.11	0.11	0.31	0.12
3	0.06	0.16	0.11	0.11	0.11	0.31	0.12
4	0.07	0.16	0.12	0.12	0.11	0.32	0.13
5	0.07	0.16	0.12	0.12	0.12	0.32	0.14
6	0.07	0.16	0.12	0.12	0.12	0.32	0.15
7	0.08	0.16	0.13	0.13	0.12	0.33	0.16
8	0.08	0.17	0.13	0.13	0.12	0.33	0.16
9	0.08	0.17	0.14	0.14	0.13	0.34	0.17
10	0.09	0.17	0.14	0.14	0.13	0.34	0.18
11	0.09	0.17	0.14	0.14	0.13	0.34	0.19
12	0.09	0.17	0.15	0.15	0.14	0.35	0.20
13	0.09	0.18	0.15	0.15	0.14	0.35	0.20
14	0.10	0.18	0.16	0.16	0.14	0.36	0.21
15	0.10	0.18	0.16	0.16	0.15	0.36	0.22
16	0.10	0.18	0.16	0.16	0.15	0.36	0.23
17	0.11	0.18	0.17	0.17	0.15	0.37	0.24
18	0.11	0.19	0.17	0.17	0.15	0.37	0.24
19	0.11	0.19	0.18	0.18	0.16	0.38	0.25
20	0.12	0.19	0.18	0.18	0.16	0.38	0.26
21	0.12	0.19	0.18	0.18	0.16	0.38	0.27

Table 3: Summary of the standard uncertainties (in μm) for the above calibration data

In Fig. 4 the data of all participants are plotted versus the reference value (see section 9). The uncertainties are omitted for clarity.

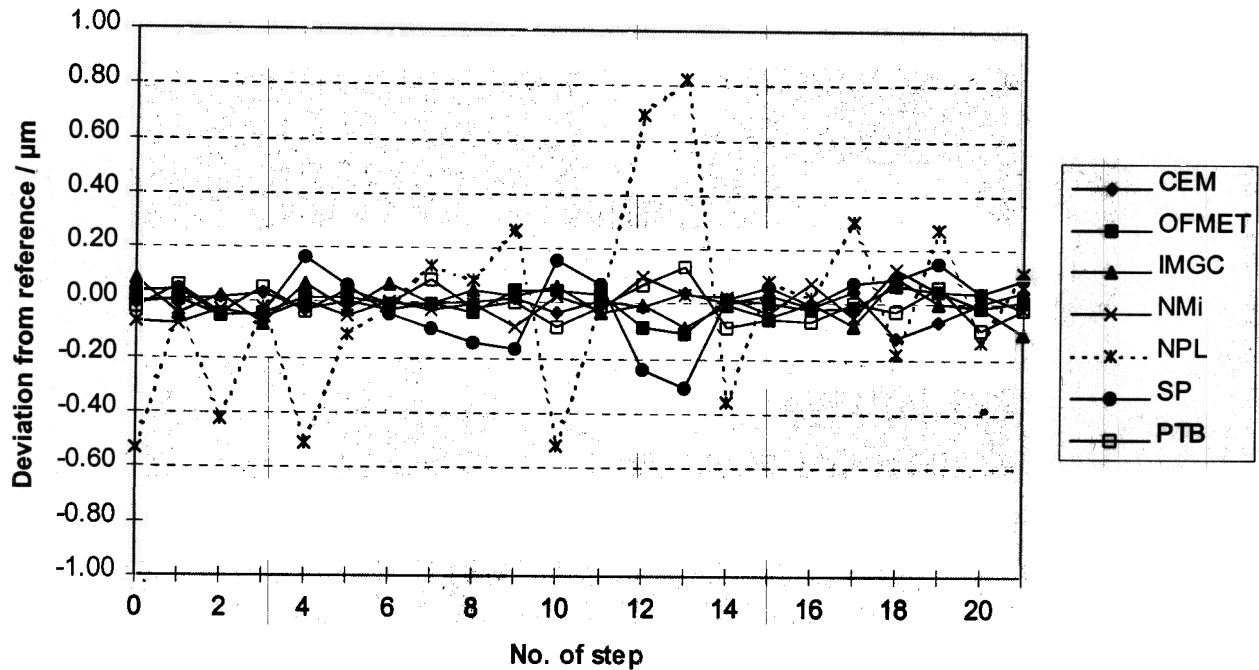

Fig. 4: Step-gauge calibration data of all participants as deviations from reference values

It can be seen that the NPL-data deviates the most from those of the other participants. This was expected by NPL, because of serious technical problems during the calibration. The peak height at steps 12 & 13 gives rise to the assumption that NPL calibrated approximately 1 mm above the intended center line.

The data of the other participants lies inside a band of about $\pm 0,2 \mu\text{m}$ which is significantly smaller than most of the uncertainties.

At SP's data there is a significant but small negative peak at the crucial 12 & 13 step position. It can be estimated that SP calibrated approximately 0,2 mm below the center line.

In the following viewgraphs the data of the individual participants are plotted versus the reference value. The error bars visualise the value of the standard uncertainty.

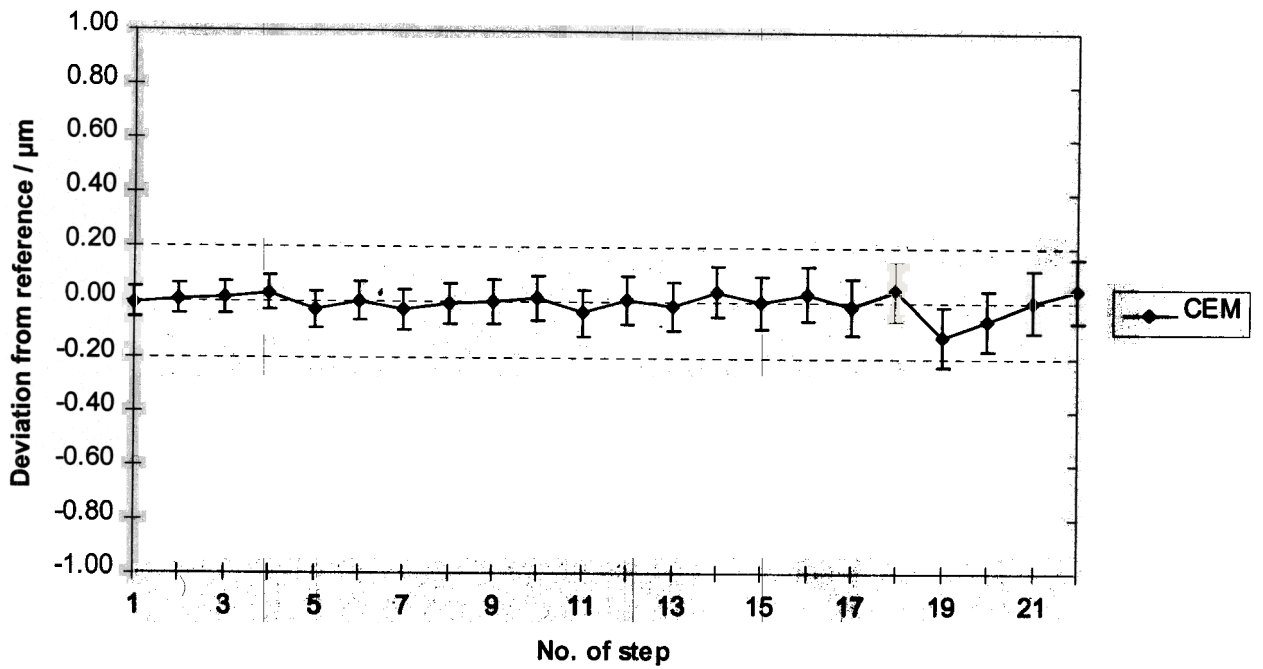

Fig. 5: CEM calibration (deviation from reference)

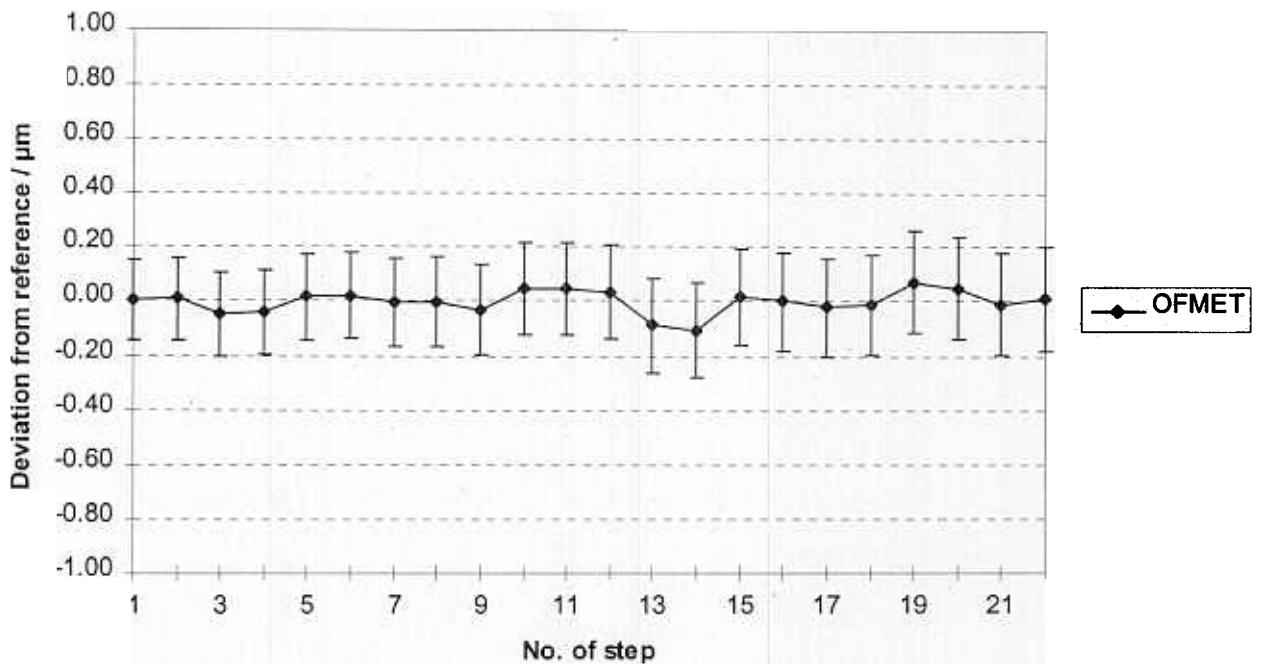

Fig. 6: OFMET calibration (deviation from reference)

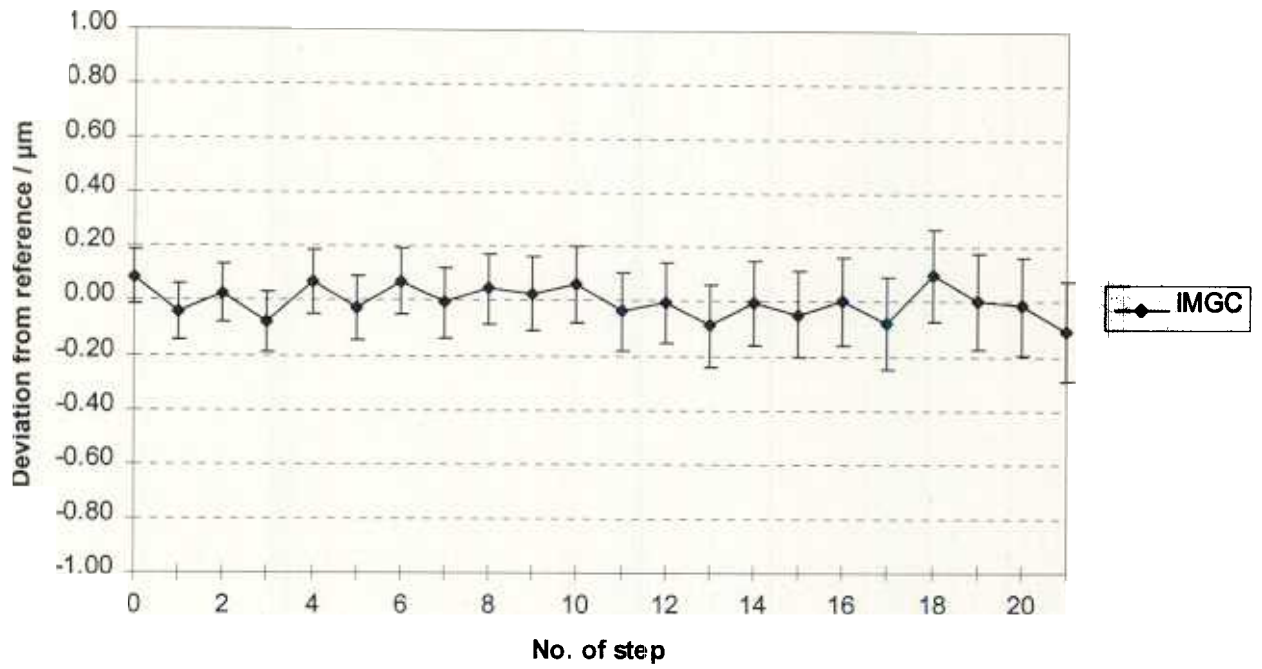

Fig. 7: IMGC calibration (deviation from reference)

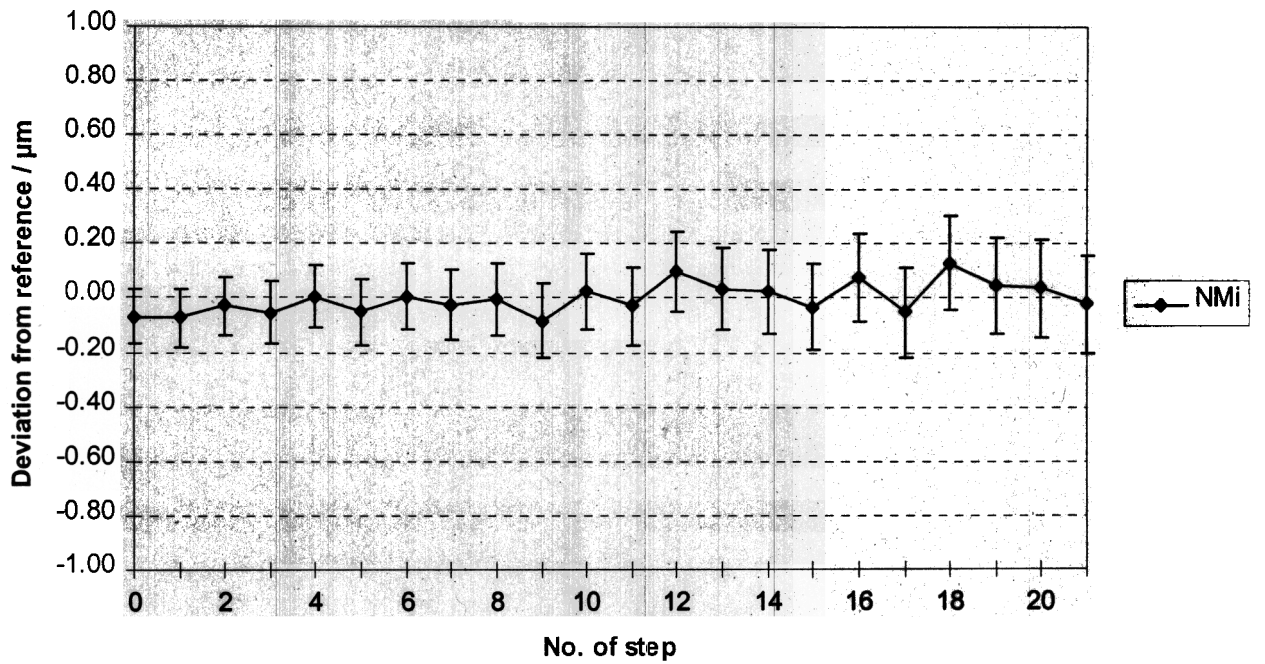

Fig. 8: NMI calibration (deviation from reference)

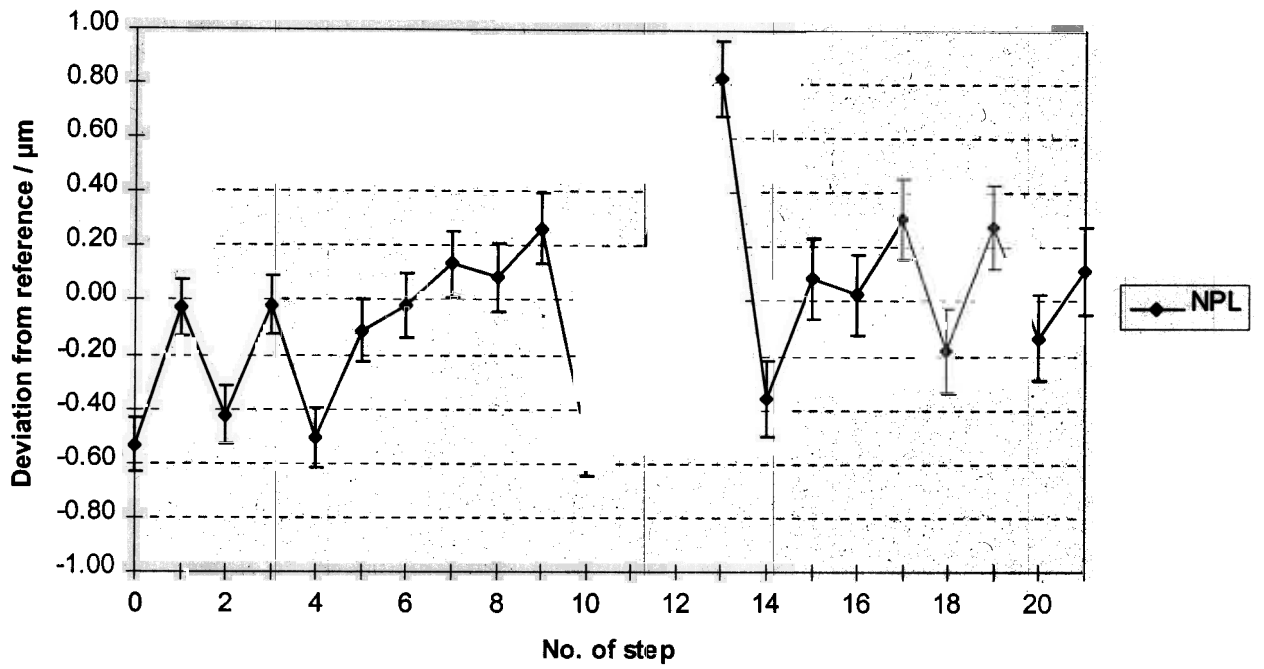

Fig. 9: NPL calibration (deviation from reference)

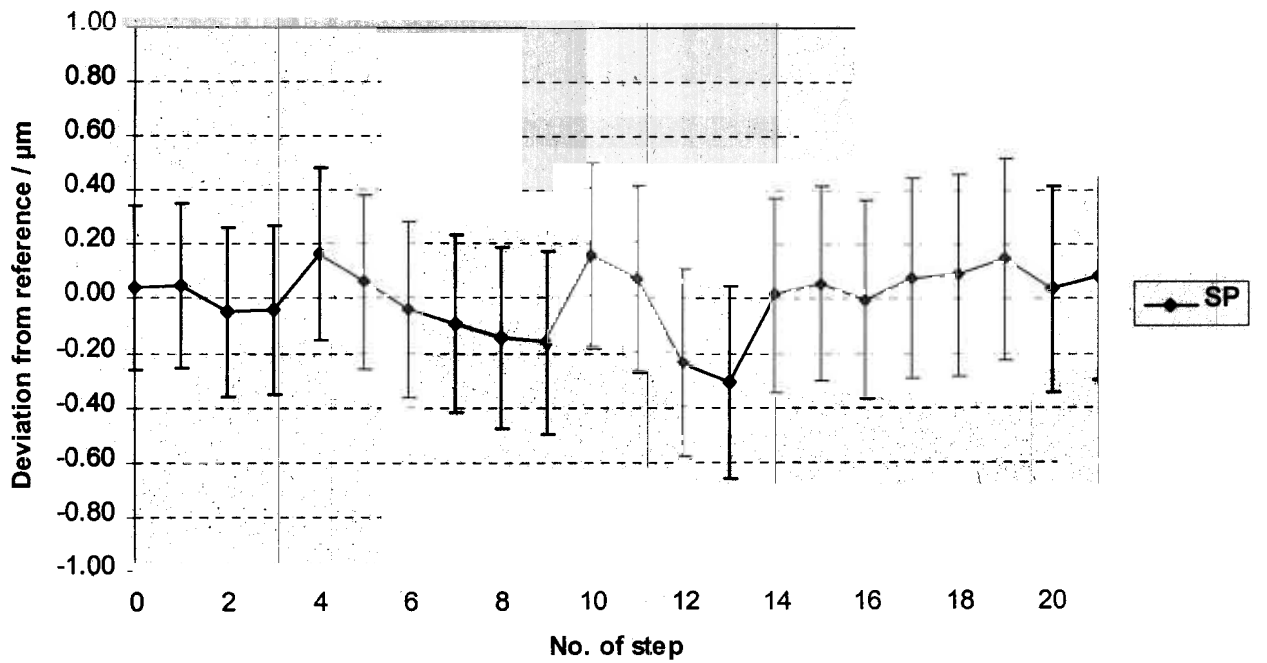

Fig. 10: SP calibration (deviation from reference)

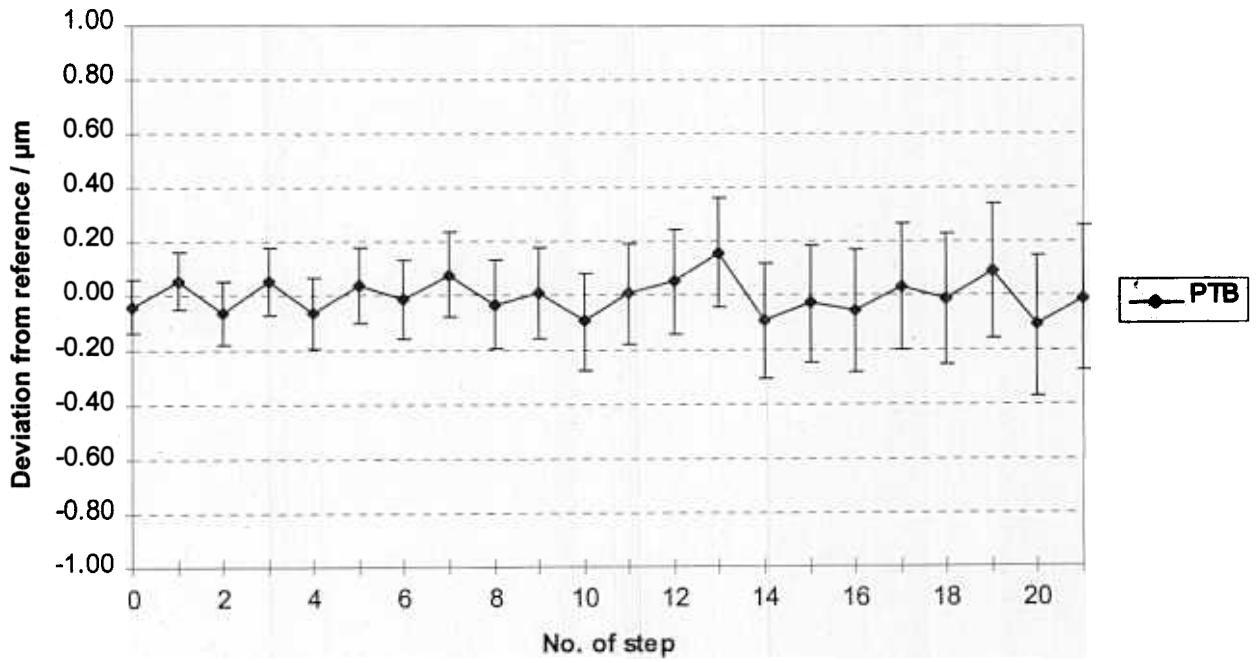

Fig. 11: PTB calibration (deviation from reference)

9 Evaluation of the reference results

From all reported data files their individual mean was subtracted. Such the constant offset is discarded. The reference values x_{ref} were calculated by the mean of all measurement values x_i of a certain step weighted by the inverse square of the standard uncertainties $u(x_i)$ associated to the measurements. The standard uncertainties $u(x_{ref})$ of the reference values are calculated by appropriately combining the individual uncertainties according to the equation below.

$$x_{ref} = \frac{\sum_{i=1}^n u^{-2}(x_i) \cdot x_i}{\sum_{i=1}^n u^{-2}(x_i)} \quad u(x_{ref}) = \left(\sum_{i=1}^n u^{-2}(x_i) \right)^{-1/2}$$

It was decided to exclude NPL's data from the reference weighting, because their data would influence the mean by a not acceptable amount.

PTB only contributes to the reference value with the data of its first calibration (1996).

10 Measurement uncertainty

There was no request for an uncertainty evaluation following the *ISO-Guide to the expression of uncertainty in measurement*, although most participants explicitly stated to follow this approach. In most certificates there was only a summary of the uncertainty but no transparent evaluation.

An example for a positive exception is the evaluation of CEM:

		Contribution	u_i^2	
u_A		- Repeatability	2401 nm ²	
u_B	u_{B1}	- Wavelength of the laser	$45 \times 10^{-18} L^2$	
	u_{B2}	- Measuring resolution (piezos + display)	16 nm ²	
	u_{B3}	- Optics linearity	6 nm ²	
	u_{B4}	- Ambient conditions		$8\,281 \times 10^{-18} L^2$
		Edlèn formula (for the initial value)		$2,5 \times 10^{-15} L^2$
		Tracker (next updated values)		$5,7 \times 10^{-15} L^2$
	u_{B5}	- Expansion coefficient of the frame of the step		$13\,456 \times 10^{-18} L^2$
	u_{B6}	- Thermal shift of optics	25 nm ²	
	u_{B7}	- Dead path	36 nm ²	
	u_{B8}	- Abbe error	0 nm ²	
	u_{B9}	- Cosine error (dynamics of the comparator)		$400 \times 10^{-18} L^2$
	u_{B10}	- Misalignment of the step (maximum)	4 nm ²	
	u_{B11}	- Inductive probes (lever type)	16 nm ²	
u_{B12}	- Reference standard gauge	144 nm ²		
	(calibration + dimensional variation between calibrations)			
u_{B13}	- Quality of measuring faces	64 nm ²		
		$\Sigma u_i^2 =$	2712 nm ² $22\,182 \times 10^{-18} L^2$	

- For $L = 0 \Rightarrow \Sigma u_i^2 = 2712 \text{ nm}^2$ $u = 52,08 \text{ nm}$

For $L = 1000 \text{ mm} \Rightarrow \Sigma u_i^2 = 2712 \text{ nm}^2 + 22\,182 \text{ nm}^2$ $u = 157,78 \text{ nm}$

The increment of uncertainty from 0 mm to 1000 mm is: $157,78 - 52,08 = 105,70 \text{ nm}$.

Then, the expression for uncertainty is:

$$u = 52,08 \text{ nm} + 0,106 \cdot 10^{-6} L$$

The expanded uncertainty for a coverage factor $k = 2$ is:

$$U = 104,16 \text{ nm} + 0,212 \cdot 10^{-6} L$$

Another example for a typical explicit uncertainty budget of this intercomparison is the SP evaluation:

Calibration of feeler constant (diameter).....	0,1 μm
Repeatability	0,2 μm
Deformation	0,2 μm
Alignment	$0,005 * 10^{-6} * L$
Refraction of air	$0,15 * 10^{-6} * L$
Temperature	$0,15 * 10^{-6} * L$

Total combined uncertainty (root mean square sum) = $0,3 + 0,2 * 10^{-6} * L$

It can be seen that the contributions do not completely cover the same contributions. Therefore a comparison of the uncertainty budgets is difficult. But one important contribution which is missing in most budgets should be mentioned.

In the above examples the alignment contribution was estimated to be 2 nm and $0,005 * 10^{-6} * L$. Similar contributions were stated by other participants. But as was emphasised in the uncertainty budget of OFMET the poor alignment quality of the chosen step-gauge (see section 7) introduces a much larger contribution to the overall uncertainty.

If the height alignment would for example fail by 0,5 mm, which is a likely assumption for some of the instruments used for this comparison, then the calibrated value of step 13 would differ by approx. 0,7 μm . Such the uncertainty budget should be dominated by the influence of the alignment uncertainty.

Annex 1 : Second measurement of NPL

During the main measurement campaign NPL already reported technical problems. Some of them were caused by alignment difficulties. It was therefore decided to let NPL measure the step-gauge once again. This second measurement took place between February and April 1999. The results are compiled into this chapter.

At first, it has to be taken into account that the reference values slightly changed by the introduction of the new NPL results (see Table 4).

Second, now it can be stated that the new results perfectly agree to the others. Such EUROMET's step-gauge measurement capabilities were harmonised.

No. of step	CEM	OFMET	IMGC	NMI	NPL	SP	PTB	Reference
0	0.00000	0.00000	0.00000	0.00000	0.00000	0.00000	0.00000	0.00000
1	20.00091	20.00090	20.00077	20.00089	20.00100	20.00090	20.00098	20.00090
2	39.95241	39.95234	39.95233	39.95243	39.95240	39.95230	39.95237	39.95239
3	59.95332	59.95324	59.95312	59.95330	59.95350	59.95320	59.95336	59.95329
4	79.99445	79.99449	79.99446	79.99455	79.99460	79.99460	79.99446	79.99448
5	99.99449	99.99450	99.99437	99.99450	99.99470	99.99450	99.99455	99.99449
6	120.03566	120.03568	120.03567	120.03576	120.03580	120.03560	120.03570	120.03569
7	140.03613	140.03613	140.03604	140.03618	140.03640	140.03600	140.03624	140.03615
8	160.07659	160.07655	160.07654	160.07665	160.07680	160.07640	160.07658	160.07659
9	180.07712	180.07715	180.07705	180.07709	180.07730	180.07690	180.07713	180.07711
10	200.11075	200.11083	200.11076	200.11088	200.11100	200.11090	200.11072	200.11080
11	220.10778	220.10780	220.10765	220.10781	220.10800	220.10780	220.10778	220.10778
12	240.12357	240.12349	240.12349	240.12375	240.12390	240.12330	240.12366	240.12360
13	260.12439	260.12424	260.12417	260.12445	260.12480	260.12400	260.12450	260.12438
14	280.14243	280.14244	280.14234	280.14252	280.14260	280.14240	280.14236	280.14244
15	300.14252	300.14248	300.14235	300.14252	300.14270	300.14250	300.14245	300.14250
16	320.07983	320.07982	320.07976	320.07999	320.08010	320.07980	320.07980	320.07986
17	340.08061	340.08055	340.08040	340.08058	340.08090	340.08060	340.08059	340.08059
18	360.12313	360.12332	360.12326	360.12345	360.12360	360.12330	360.12324	360.12328
19	380.12403	380.12414	380.12401	380.12421	380.12460	380.12420	380.12417	380.12413
20	400.13871	400.13869	400.13860	400.13881	400.13890	400.13870	400.13863	400.13872
21	420.13950	420.13946	420.13926	420.13950	420.13970	420.13950	420.13945	420.13947

Table 4: Summary of the reported calibration results of the step-gauge with new NPL data and new calculated reference values (in mm)

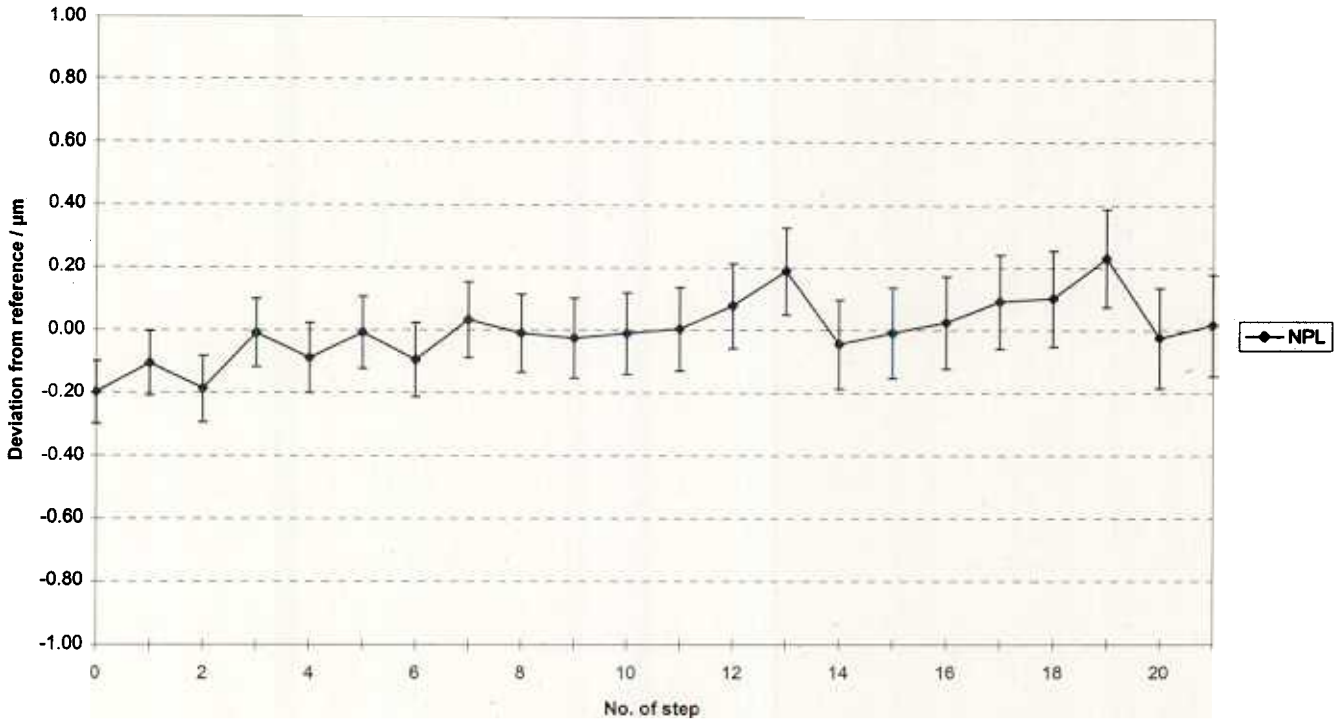

Fig.12 New NPL data vs. updated reference

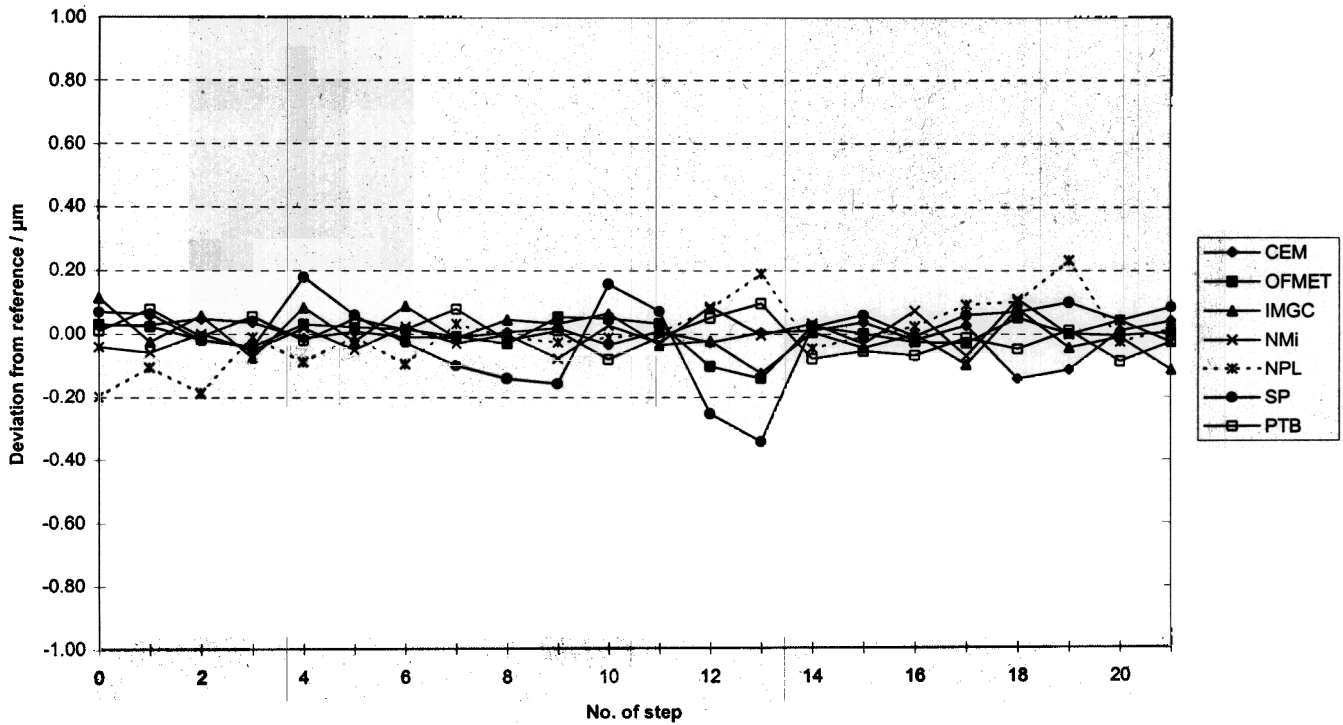

Fig.13 All data vs. updated reference